



FUNCTIONAL SKILLS MATHS & ENGLISH

LEVEL 1 & 2 EXAMS

Functional Skills Maths & English Exams

Exam Centre is a specialist provider of **Functional Skills** qualifications in **Maths** and **English**, offering **City & Guilds** examinations that are fully regulated and **approved by Ofqual**.

Our Functional Skills qualifications are recognised as equivalent to **GCSE grade 4+ (grade C and above)**, providing learners with a credible and nationally accepted route into further education, apprenticeships, and employment.

[BOOK NOW](#)

[LEARN MORE](#)

Online Courses

- ➔ Functional Skills Maths
- ➔ Functional Skills English

Exams

- ➔ Functional Skills **Maths** Level 1 or 2 Exams **in London**
- ➔ Functional Skills **English** Level 1 or 2 Exam **in London**
- ➔ **Online** Functional Skills **Maths** Level 1 or 2 Exams
- ➔ **Online** Functional Skills **English** Level 1 or 2 Exam

***Disclaimer:** The content of this document belongs to the respective awarding body and is shared for educational purposes only, Exam Centre does not claim ownership of this material.*



www.examcentre.co.uk



362 Essex Road
Islington N1 3PD



020 7288 9020

BOOK YOUR FUNCTIONAL SKILLS EXAM NOW!

Please check the examination details below before entering your candidate information

Candidate surname

Other names

**Pearson Edexcel
Functional Skills**

Centre Number

Candidate Number

*****Past Paper 3*****

Time: 25 minutes

Paper Reference **PMAT2/N03**

Mathematics

Level 2

Section A (Non-Calculator)



You must have:

Pen, HB pencil, eraser, ruler graduated in cm and mm, protractor,
pair of compasses. Tracing paper may be used.

Total Marks

My signature confirms that I will not discuss the content of the test with anyone.

Signature: _____

Instructions

- Use **black** ink or ball-point pen.
- **Fill in the boxes** at the top of this page with your name, centre number and candidate number.
- Sign the declaration.
- Answer **all** questions.
- Write your final answers in the boxes provided.
- Answer the questions in the spaces provided – *there may be more space than you need.*
- You **must** show clearly how you get your answers in the spaces provided. Marks will be awarded for your working out.
- Check your working and answers at each stage.
- Diagrams are **not** accurately drawn, unless otherwise indicated.
- **Calculators may not be used.**
- Take the value of π to be 3.14

Information

- The total mark for this section is 16.
- The marks for **each** question are shown in brackets – *use this as a guide as to how much time to spend on each question.*
- This sign shows where marks will be awarded for showing your checks.

Advice

- Read each question carefully before you start to answer it.
- Check your answers if you have time at the end.

Turn over ►

P64960A

©2019 Pearson Education Ltd.

1/1/1



Pearson



DO NOT WRITE IN THIS AREA

DO NOT WRITE IN THIS AREA

DO NOT WRITE IN THIS AREA

DO NOT WRITE IN THIS AREA

DO NOT WRITE IN THIS AREA

DO NOT WRITE IN THIS AREA

BLANK PAGE



SECTION A

Answer ALL questions. Write your answers in the spaces provided.

- 1** Kate is making some pastry.
She will use 20 ounces of flour.

Kate has a recipe that uses 8 ounces of flour with 3 ounces of butter.

Work out how many ounces of butter Kate needs to use.

(3)

ounces

(Total for Question 1 is 3 marks)

DO NOT WRITE IN THIS AREA

DO NOT WRITE IN THIS AREA

DO NOT WRITE IN THIS AREA

DO NOT WRITE IN THIS AREA

DO NOT WRITE IN THIS AREA

DO NOT WRITE IN THIS AREA



2

(a) Work out the value of $4x + 3$ when $x = 2$

(1)

Here is a formula

$$A = 5\sqrt{B}$$

(b) Work out the value of A when $B = 16$

(2)

(Total for Question 2 is 3 marks)

DO NOT WRITE IN THIS AREA

DO NOT WRITE IN THIS AREA

DO NOT WRITE IN THIS AREA

DO NOT WRITE IN THIS AREA

DO NOT WRITE IN THIS AREA

DO NOT WRITE IN THIS AREA



DO NOT WRITE IN THIS AREA

DO NOT WRITE IN THIS AREA

DO NOT WRITE IN THIS AREA

DO NOT WRITE IN THIS AREA

DO NOT WRITE IN THIS AREA

DO NOT WRITE IN THIS AREA

3

(a) Work out $\frac{5}{8}$ of 320

(2)

Kanya makes and sells jewellery items.

In one week she sells earrings, bracelets and necklaces in the ratio 13:24:15

(b) What fraction of the total items sold were bracelets?
Give your answer in its simplest form.

(2)

—

(Total for Question 3 is 4 marks)



4 Paul sees this advert for a payment plan for a laptop.

Laptop payment plan

normal price £240

pay a deposit of £36 and £15 a month for 12 months

use our payment plan and save 8% of the normal price

(a) Does using the payment plan save 8% of the normal price?
You **must** show your working.

(5)

DO NOT WRITE IN THIS AREA

DO NOT WRITE IN THIS AREA

DO NOT WRITE IN THIS AREA

DO NOT WRITE IN THIS AREA

DO NOT WRITE IN THIS AREA

DO NOT WRITE IN THIS AREA



DO NOT WRITE IN THIS AREA

DO NOT WRITE IN THIS AREA

DO NOT WRITE IN THIS AREA

DO NOT WRITE IN THIS AREA

DO NOT WRITE IN THIS AREA

DO NOT WRITE IN THIS AREA



(b) Use estimation to check your calculation for the cost of the payment plan.

(1)

(Total for Question 4 is 6 marks)

TOTAL FOR SECTION A IS 16 MARKS



BLANK PAGE

DO NOT WRITE IN THIS AREA

DO NOT WRITE IN THIS AREA

DO NOT WRITE IN THIS AREA

DO NOT WRITE IN THIS AREA

DO NOT WRITE IN THIS AREA

DO NOT WRITE IN THIS AREA



Please check the examination details below before entering your candidate information

Candidate surname

Other names

**Pearson Edexcel
Functional Skills**

Centre Number

Candidate Number

*****Past Paper 3*****

Time: 1 hour 30 minutes

Paper Reference **PMAT2/C03**

Mathematics

Level 2

Section B (Calculator)



You must have:

Pen, HB pencil, eraser, ruler graduated in cm and mm, protractor, pair of compasses. Tracing paper may be used.

Total Marks

My signature confirms that I will not discuss the content of the test with anyone.

Signature: _____

Instructions

- Use **black** ink or ball-point pen.
- **Fill in the boxes** at the top of this page with your name, centre number and candidate number.
- Sign the declaration.
- Answer **all** questions.
- Write your final answers in the boxes provided.
- Answer the questions in the spaces provided – *there may be more space than you need.*
- You **must** show clearly how you get your answers in the spaces provided. Marks will be awarded for your working out.
- Check your working and answers at each stage.
- Diagrams are **not** accurately drawn, unless otherwise indicated.
- **Calculators may be used.**
- If your calculator does not have a π button take the value of π to be 3.14

Information

- The total mark for this section is 48.
- The total mark for this paper is 64.
- The marks for **each** question are shown in brackets – *use this as a guide as to how much time to spend on each question.*
- This sign shows where marks will be awarded for showing your checks.

Advice

- Read each question carefully before you start to answer it.
- Check your answers if you have time at the end.

Turn over ►

P64961A

©2019 Pearson Education Ltd.

1/1/1





Pearson

SECTION B

Answer ALL questions. Write your answers in the spaces provided.

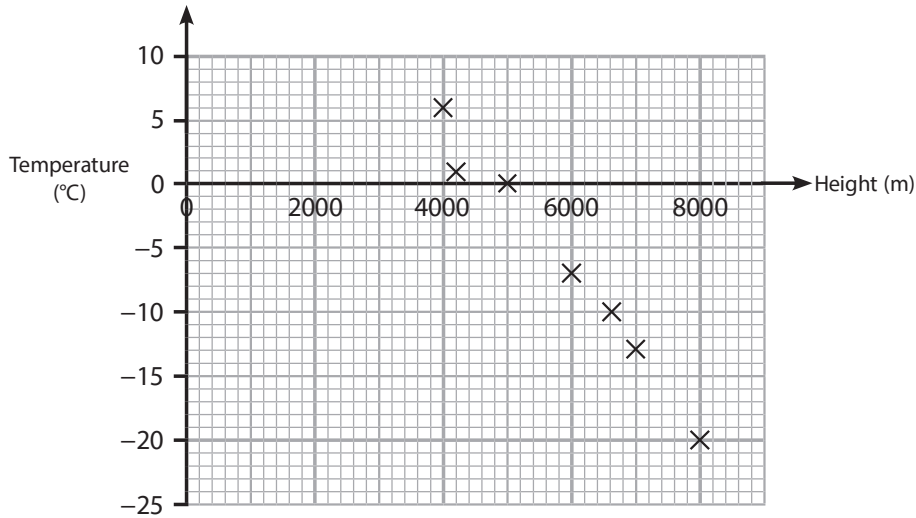
- 1 The scatter diagram shows the temperature at different heights on Mount Everest for one afternoon in May.



(a) Describe the relationship shown in this scatter diagram.

(1)

There are camps on Mount Everest.

Base camp A is at a height of 5400m.

Camp 3 is at a height of 7500m.

(b) Use the scatter diagram to work out the difference in temperatures between the two camps.

(2)

(Total for Question 1 is 3 marks)

DO NOT WRITE IN THIS AREA

DO NOT WRITE IN THIS AREA

DO NOT WRITE IN THIS AREA

DO NOT WRITE IN THIS AREA

DO NOT WRITE IN THIS AREA

DO NOT WRITE IN THIS AREA



DO NOT WRITE IN THIS AREA

DO NOT WRITE IN THIS AREA

DO NOT WRITE IN THIS AREA

DO NOT WRITE IN THIS AREA

DO NOT WRITE IN THIS AREA

DO NOT WRITE IN THIS AREA

- 2 Jenni is an editor for a newspaper.
She checks information in an article.

The article states, 'In 2019 there were 300 people per square kilometre in the UK'

Jenny knows that in 2019

- the area of the UK was 242 500 square kilometres
- the population of the UK was 66.9 million.

- (a) Is the statement in the article correct?
Show why you think this.

(2)



- (b) Use a reverse calculation to show a check of your answer.

(1)

(Total for Question 2 is 3 marks)



3 Wesley is a salesman.

He wants to work out the total cost of the petrol he will use for travel next week.

Wesley knows

- he will drive a total of 520 miles
- his car uses 1 gallon of petrol per 28 miles
- petrol costs 128.4 pence per litre
- 1 gallon = 4.55 litres.

Wesley thinks the petrol he will use for travel next week will cost more than £100

Is Wesley correct?
Show why you think this.

(4)

(Total for Question 3 is 4 marks)

DO NOT WRITE IN THIS AREA

DO NOT WRITE IN THIS AREA

DO NOT WRITE IN THIS AREA

DO NOT WRITE IN THIS AREA

DO NOT WRITE IN THIS AREA

DO NOT WRITE IN THIS AREA



DO NOT WRITE IN THIS AREA

DO NOT WRITE IN THIS AREA

DO NOT WRITE IN THIS AREA

DO NOT WRITE IN THIS AREA

DO NOT WRITE IN THIS AREA

DO NOT WRITE IN THIS AREA

4 Anwar makes a playhouse for his children.

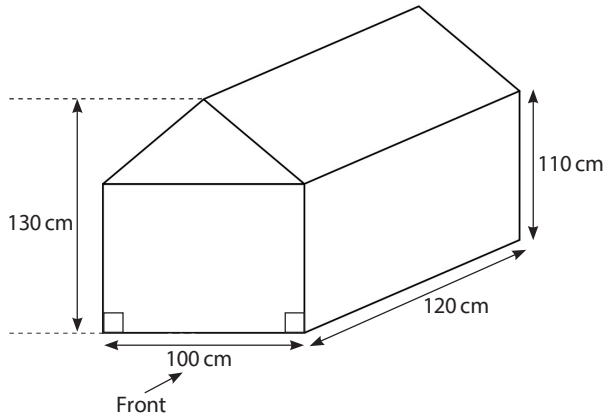

The front elevation of the playhouse has one line of symmetry.

Draw the front elevation of the playhouse on the grid.
Use the scale 1 : 20

(3)

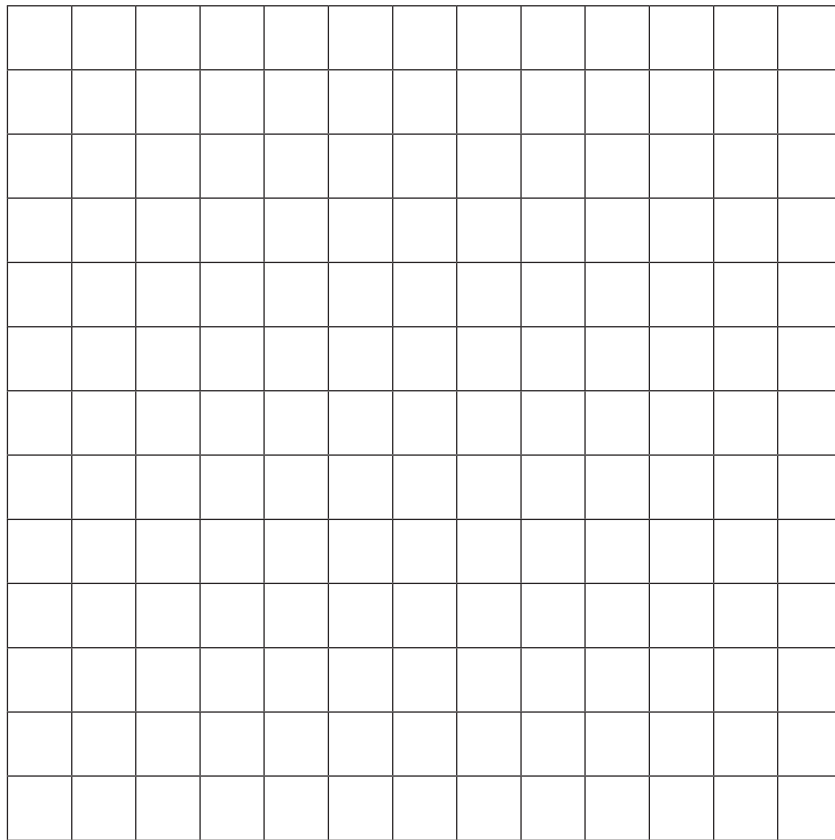

(Total for Question 4 is 3 marks)



5 In October Mr Barker gave a group of 250 students a history test.

These are the results.

Number of marks	Frequency		
1 to 5	20		
6 to 10	50		
11 to 15	120		
16 to 20	60		

Mr Barker estimates the mean mark to be 12

(a) Is Mr Barker correct?
Show why you think this.

(3)

DO NOT WRITE IN THIS AREA

DO NOT WRITE IN THIS AREA

DO NOT WRITE IN THIS AREA

DO NOT WRITE IN THIS AREA

DO NOT WRITE IN THIS AREA

DO NOT WRITE IN THIS AREA



DO NOT WRITE IN THIS AREA

DO NOT WRITE IN THIS AREA

DO NOT WRITE IN THIS AREA

DO NOT WRITE IN THIS AREA

DO NOT WRITE IN THIS AREA

DO NOT WRITE IN THIS AREA

In the October test the lowest mark was 2 and the highest mark was 17

In November the same students took a similar test.
The lowest mark was 5 and the highest mark was 18

Mr Barker wants to write a statement comparing the spread of marks in the two tests.

- (b) Write a statement to compare the spread of marks in the two tests.
You **must** show calculations to support your statement.

(2)

(Total for Question 5 is 5 marks)



- 6 Mia is the manager of an ice cream shop.
In August she sold 960 ice lollies.
In September she sold 810 ice lollies.

Mia thinks she sold 18% fewer ice lollies in September than in August.

Did Mia sell 18% fewer ice lollies in September than in August?

(3)

(Total for Question 6 is 3 marks)

DO NOT WRITE IN THIS AREA

DO NOT WRITE IN THIS AREA

DO NOT WRITE IN THIS AREA

DO NOT WRITE IN THIS AREA

DO NOT WRITE IN THIS AREA

DO NOT WRITE IN THIS AREA



- 7 Alex has two sets of four cards.
He writes a number on each card.

Alex picks one card from each set and multiplies the numbers to get a score.

The table shows some of the scores.

Card 1

\times	-5	7	-9	11
2	-10	14		22
4		28	-36	
-6	30	-42		
8	-40	56		

Card 2

- (a) Complete the table.

(2)

Alex says,

'The probability that the score is negative is 0.5, which means there is a 5% chance that the score is negative.'

- (b) Alex is incorrect.
Explain why.

(1)

Alex picks one card from each set.

- (c) What is the probability that the score is 14?

(1)

(Total for Question 7 is 4 marks)



- 8 Abi has a mirror in the shape of a rectangle with a semicircle on one of the shorter edges.
The radius of the semicircle is 30 cm.
The longer edge of the rectangle is 85 cm.

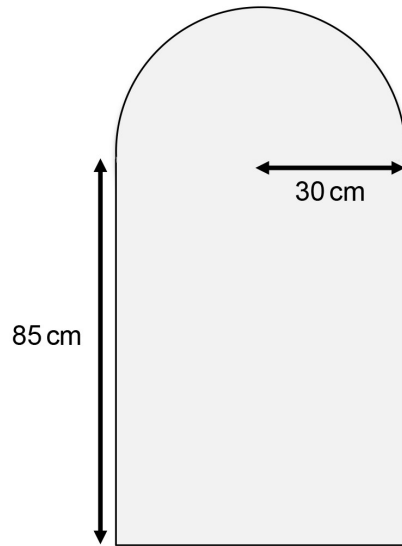

Abi buys a 500cm length of mirror trim to go around all the edges of the mirror.

She thinks she will use more than $\frac{2}{3}$ of the length of the mirror trim.

Is Abi correct?
Show why you think this.

(6)

DO NOT WRITE IN THIS AREA

DO NOT WRITE IN THIS AREA

DO NOT WRITE IN THIS AREA

DO NOT WRITE IN THIS AREA

DO NOT WRITE IN THIS AREA

DO NOT WRITE IN THIS AREA



DO NOT WRITE IN THIS AREA

DO NOT WRITE IN THIS AREA

DO NOT WRITE IN THIS AREA

DO NOT WRITE IN THIS AREA

DO NOT WRITE IN THIS AREA

DO NOT WRITE IN THIS AREA

Large empty rectangular area for writing answers.

(Total for Question 8 is 6 marks)



9 Karl plots 3 points on a grid.

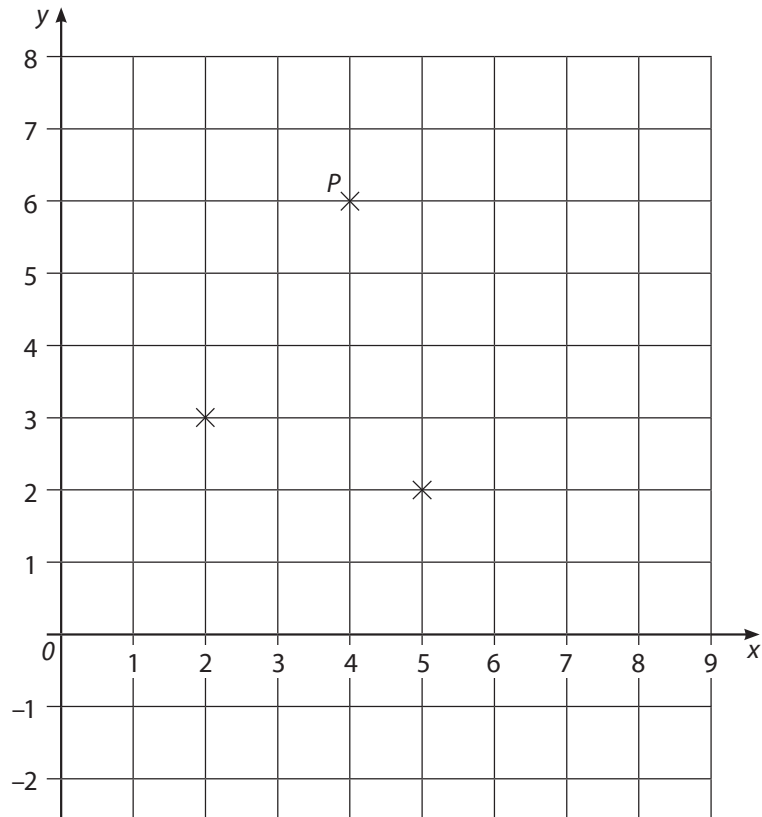

(a) Write down the coordinates of the point *P*.

(1)

Karl plots another point.
He joins the four points to make a parallelogram.

(b) Write down a possible set of coordinates for the fourth point.
Plot the point on the grid.

(2)

(Total for Question 9 is 3 marks)

DO NOT WRITE IN THIS AREA

DO NOT WRITE IN THIS AREA

DO NOT WRITE IN THIS AREA

DO NOT WRITE IN THIS AREA

DO NOT WRITE IN THIS AREA

DO NOT WRITE IN THIS AREA



DO NOT WRITE IN THIS AREA

DO NOT WRITE IN THIS AREA

DO NOT WRITE IN THIS AREA

DO NOT WRITE IN THIS AREA

DO NOT WRITE IN THIS AREA

DO NOT WRITE IN THIS AREA

10 Andy and his brother set up eco cabins.
It takes the 2 of them 6 days to set up one eco cabin.

A friend starts working with them.

How many days will 3 people take to set up one eco cabin?

(3)

days

(Total for Question 10 is 3 marks)



11 Gavin is a car salesman.

The table shows the number of cars he sold in one week.

Mon	Tue	Wed	Thu	Fri	Sat
2	0	1	4	1	2

The cost of each car is £20 950

For every car Gavin sells he earns

- 1.25% of the cost of the car in commission
- a bonus of £50

Work out the median amount Gavin earned per day for this week.

(5)

DO NOT WRITE IN THIS AREA

DO NOT WRITE IN THIS AREA

DO NOT WRITE IN THIS AREA

DO NOT WRITE IN THIS AREA

DO NOT WRITE IN THIS AREA

DO NOT WRITE IN THIS AREA



DO NOT WRITE IN THIS AREA

DO NOT WRITE IN THIS AREA

DO NOT WRITE IN THIS AREA

DO NOT WRITE IN THIS AREA

DO NOT WRITE IN THIS AREA

DO NOT WRITE IN THIS AREA

Blank area for student response.

£

(Total for Question 11 is 5 marks)



- 12 Maninder is the manager of a restaurant.
She wants to cover the floor of the restaurant with tiles.

This is a plan of the floor of the restaurant.

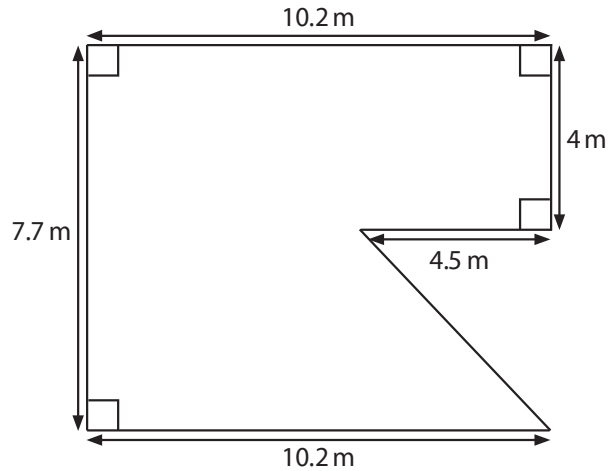

Maninder will buy the tiles in packs.
Each pack covers an area of 0.945 m^2
One pack of tiles costs £16.15

Tiles can be cut and joined.

Work out the total cost of the packs of tiles Maninder will buy.

(6)

DO NOT WRITE IN THIS AREA

DO NOT WRITE IN THIS AREA

DO NOT WRITE IN THIS AREA

DO NOT WRITE IN THIS AREA

DO NOT WRITE IN THIS AREA

DO NOT WRITE IN THIS AREA



DO NOT WRITE IN THIS AREA

DO NOT WRITE IN THIS AREA

DO NOT WRITE IN THIS AREA

DO NOT WRITE IN THIS AREA

DO NOT WRITE IN THIS AREA

DO NOT WRITE IN THIS AREA

Blank area for student response.

£

(Total for Question 12 is 6 marks)

TOTAL FOR SECTION B IS 48 MARKS
TOTAL FOR PAPER IS 64 MARKS



BLANK PAGE

DO NOT WRITE IN THIS AREA

DO NOT WRITE IN THIS AREA

DO NOT WRITE IN THIS AREA

DO NOT WRITE IN THIS AREA

DO NOT WRITE IN THIS AREA

DO NOT WRITE IN THIS AREA



DO NOT WRITE IN THIS AREA

DO NOT WRITE IN THIS AREA

DO NOT WRITE IN THIS AREA

DO NOT WRITE IN THIS AREA

DO NOT WRITE IN THIS AREA

DO NOT WRITE IN THIS AREA

BLANK PAGE



BLANK PAGE

DO NOT WRITE IN THIS AREA

DO NOT WRITE IN THIS AREA

DO NOT WRITE IN THIS AREA

DO NOT WRITE IN THIS AREA

DO NOT WRITE IN THIS AREA

DO NOT WRITE IN THIS AREA





Ready to Take Your Functional Skills Exam?

Exam Centre is offering Ofqual-regulated, City & Guilds approved Functional Skills Maths and English exams; the nationally recognised GCSE grade 4+ (grade C) equivalent. Whether you're sitting for the first time or resitting, we offer flexible exam bookings online and at our centre all year round.

 **Book Now!**

Book Your Exams & Courses

Qualification	Private Course	Online Exam	Exam in London
Functional Skills Maths Level 1 & 2	Enrol on Course	Book Online Exam	Book London Exam
Functional Skills English Level 1 & 2	Enrol on Course	Book Online Exam	Book London Exam

Why Exam Centre?

- Ofqual-regulated & fully accredited
- City & Guilds approved awarding body exams
- Accepted by employers, colleges, universities & apprenticeship providers
- Flexible online and in-person options across the UK
- Recognised GCSE Maths & English equivalent (grade 4+ / grade C)

CALL US FOR MORE INFORMATION:

 **020 7288 9020**

 booking@examcentre.co.uk

 www.examcentre.co.uk