



FUNCTIONAL SKILLS MATHS & ENGLISH

LEVEL 1 & 2 EXAMS

Functional Skills Maths & English Exams

Exam Centre is a specialist provider of **Functional Skills** qualifications in **Maths** and **English**, offering **City & Guilds** examinations that are fully regulated and **approved by Ofqual**.

Our Functional Skills qualifications are recognised as equivalent to **GCSE grade 4+ (grade C and above)**, providing learners with a credible and nationally accepted route into further education, apprenticeships, and employment.

[BOOK NOW](#)

[LEARN MORE](#)

Online Courses

- ➔ Functional Skills Maths
- ➔ Functional Skills English

Exams

- ➔ Functional Skills **Maths** Level 1 or 2 Exams **in London**
- ➔ Functional Skills **English** Level 1 or 2 Exam **in London**
- ➔ **Online** Functional Skills **Maths** Level 1 or 2 Exams
- ➔ **Online** Functional Skills **English** Level 1 or 2 Exam

***Disclaimer:** The content of this document belongs to the respective awarding body and is shared for educational purposes only, Exam Centre does not claim ownership of this material.*



www.examcentre.co.uk



362 Essex Road
Islington N1 3PD



020 7288 9020

BOOK YOUR FUNCTIONAL SKILLS EXAM NOW!

Duration: 1 hour 20 minutes
Total marks: 45 marks

SECTION 2 – CALCULATOR PERMITTED

Candidate name (first, last)

First

Last

Candidate enrolment number

Date of birth (DDMMYYYY)

Assessment date (DDMMYYYY)

Centre number

Candidate signature and declaration*

- If you have used any additional answer sheets write the number of additional sheets in this box.
 - Please ensure that you **staple** additional answer sheets to the **back** of this booklet, clearly labelling them with your full name, enrolment number, centre number and date in BLOCK CAPITALS.
 - You must use a black or blue pen. You may use a pencil for charts and diagrams.
- *I declare that I had no prior knowledge of the questions in this assessment and that I will not share information about the questions.**

Please check that your name is correctly printed on the candidate barcode label. If not, please tell the invigilator before the start of the exam.

You should have the following for this assessment

- a pen with black or blue ink.
- a pencil
- an eraser
- a 30cm ruler
- a calculator.

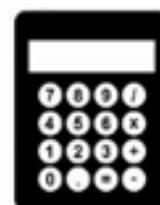

You must NOT use a protractor.

General instructions

- Read through each question carefully.
- You may use a dictionary.
- Show your working out (where required).
- Write all your working out and answers in this booklet.
- Check your calculations and check that your answers make sense.
- There are additional pages at the back of this booklet if you run out of space or ask the invigilator if you need additional sheets of paper.

SECTION 2 – CALCULATOR PERMITTED

There are **45** marks in this section.

You should check all your work as you go along.

You may use a calculator.



Q1

What is 35 as a fraction of 490? Give your answer in its simplest form.

$$\frac{\square}{\square}$$

(1 mark)

Q2

$$1\frac{3}{8} + 3\frac{9}{16} =$$

(tick one box)

A $4\frac{1}{2}$

B $4\frac{3}{8}$

C $4\frac{3}{4}$

D $4\frac{15}{16}$

(1 mark)

Q3

Which of these has the smallest value?

(tick one box)

A $6.048 \div 24$

B $0.095 \div 5$

C $1.032 \div 12$

D $1.274 \div 7$

(1 mark)

Q4

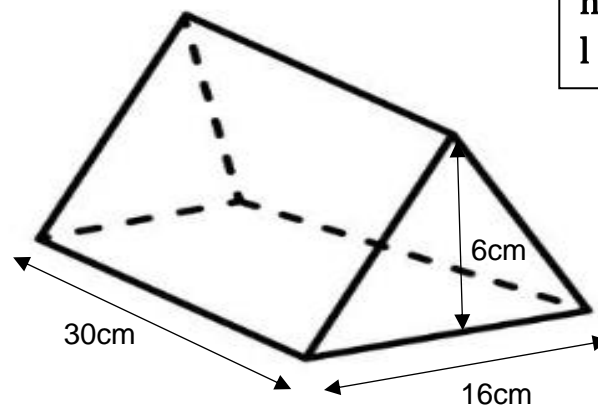

$$v = \frac{bhl}{2}$$

v = volume in cm^3
 b = base in cm
 h = height in cm
 l = length in cm

Diagram not to scale

What is the volume of this triangular prism?

_____ cm^3

(1 mark)

Q5

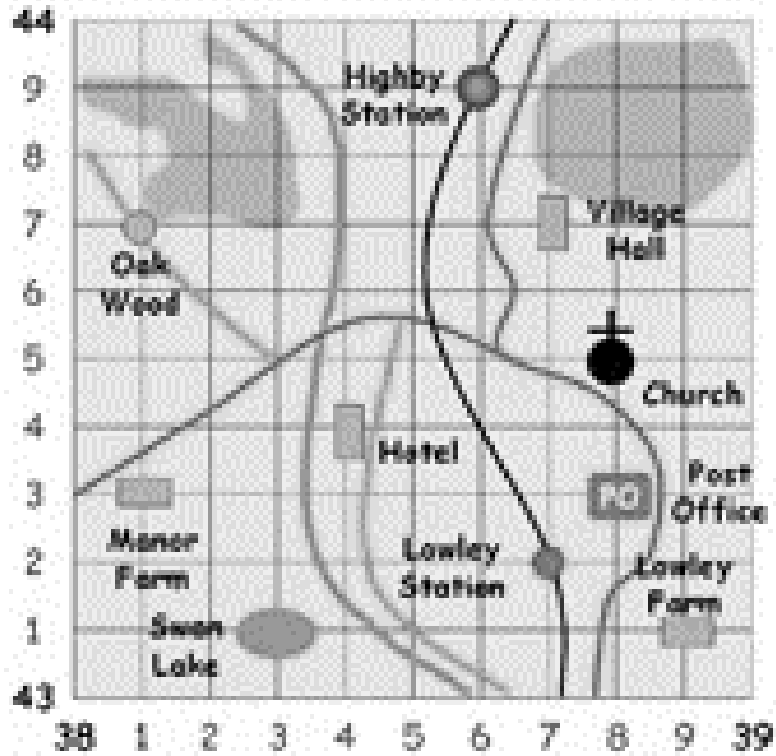

What is the coordinate for Highby Station?

(tick one box)

- A 396449
- B 386439
- C 439386
- D 449396

(1 mark)

Q6

A woman is going to Spain for a holiday.

She wants to book a hotel online.

She finds a hotel that charges €84 euros per night.

She thinks this will be about £100 per night.

Exchange rate pound to euro £1 = €1.12

Is she right? Explain your answer.

Is she right? (tick one box) Yes No

Explanation

(1 mark)

Q7

An apprentice hairdresser needs to prepare a solution to colour a client's hair.

The client wants high lift shades.

The apprentice hairdresser measures out 75ml of developer.

Hair shade	Ratio of hair colour to developer
Grey coverage and fashion shades	1 : 1
High lift shades	1 : 1.5
Hair lightener	1 : 2

What amount of hair colour should she measure out?

Show your working

_____ ml

(2 marks)

Q8

A woman has a new fitness watch.

She uses this formula to calculate her **step length**.

$$\textit{Step length(feet)} = \frac{\textit{a measured distance in feet}}{\textit{(the number of steps taken)}}$$

Her **measured distance** was **20 feet** and the number of **steps taken** was **16**.

In her first week she walks 67118 steps.

She wants to know how many kilometres she walked in the first week.

1 foot = 0.0003048km

What distance did she walk?

Show your working

Distance walked _____ km

(3 marks)

Q9

A secretary needs to order 8 boxes of paper clips. Each box costs £7.67

The table below shows the discount offered on large orders.

Total order	Discount
£40 - £54.99	5%
£55 - £79.99	6.5%
£80 or more	8%

What amount will the secretary have to pay?

Show your working

£ _____

(3 marks)

Q10

The Chairperson of a committee needs to write a report for a council meeting.

She needs to compare the fly tipping incidents reported in the **local area** with the fly tipping incidents reported **nationally**.

National Report

This year local authorities in England dealt with an **increase of 8%** of fly tipping incidents on those reported in last year.

This table shows the numbers of fly tipping incidents reported in the local area.

Year	Numbers of fly tipping incidents reported
Last year	11 193
This year	11 649

What will the Chairperson write in her report about the comparison between the local incidents and the national incidents? Explain your answer using figures.

Show your working

Explanation

(4 marks)

Q11

A golf coach wants to tell a beginner how he is performing.
He tells the beginner that he should be able to hit the ball 150 yards on average.
He tests the beginner and records the distance of each hit.

Distance travelled (d) in yards	Frequency
$135 \leq d < 140$	4
$140 \leq d < 145$	13
$145 \leq d < 150$	17
$150 \leq d < 155$	6

Is the beginner performing at the average level? Explain your answer using figures

Show your working

Is the beginner performing at the average level?

(tick one box) **Yes** **No**

Explanation

(5 marks)

Q12

A garage sells used cars.

When a customer buys a car, the garage owner will offer an amount to pay for their old car.

A customer brings in a ZZX Roadster with a mileage of 70 000.

The garage owner estimates the value of this car based on the mileage.

He uses this website graphic to find this value.

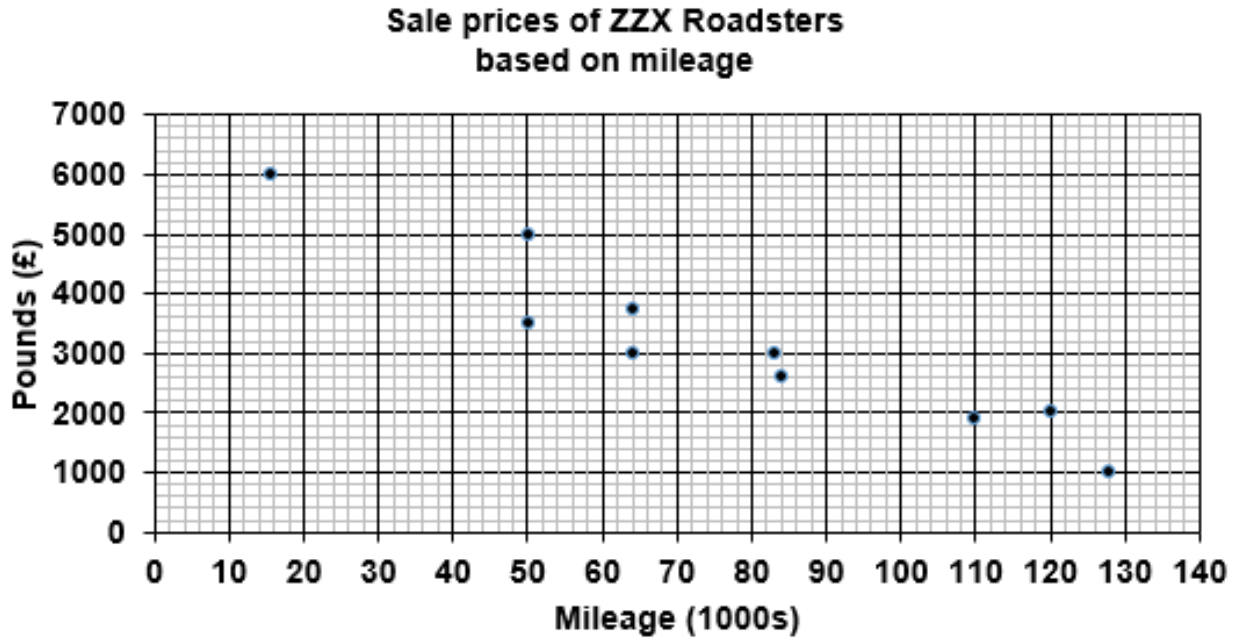

He wants to make a first offer to the customer 30% below this value in order to make a profit when he resells it.

What amount should he offer the customer?

Explain your answer by drawing a trend line and marking the graph to show how you decided the amount.

Estimated value of the customer's car £ _____

Show your working

First offer to customer £ _____

(4 marks)

Q13

A 22-year-old man wants to apply for this job.

He wants to work out how much his annual take home pay will be.

Staff required
for busy town centre retail store.

Shifts available 6am – 1pm
Includes one hour break unpaid.
6 days per week
National Minimum Wage

National Minimum Wage (NMW) rates

NMW (age)	Apprentice	16-17 years	18-20 years	21-24 years
Rate per hour (£)	£3.90	£4.35	£6.15	7.70

He knows he has to pay income tax and national insurance and what is left is his take home pay.

TAX INFORMATION

Income tax is taken from your earnings after your personal allowance has been deducted.

Income Tax rates and bands

Band	Taxable income	Tax rate
Personal allowance	up to £12 500	0%
Basic rate	£12 501 to £50 000	20%
Higher rate	£50 001 to £150 000	40%

He is told that his national insurance will be about £600 National Insurance in the year.

What will the man's annual pay be?

Show your working.

£ _____

(6 marks)

Q14

A kitchen designer needs to draw a scale plan for a customer's new kitchen.

The customer gives the kitchen designer this sketch to show how she would like the cupboards to fit above the worktop.

The base of the large cupboard needs to be 50cm above the top of the worktop.

Diagram not to scale

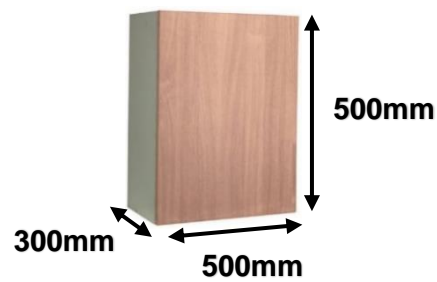
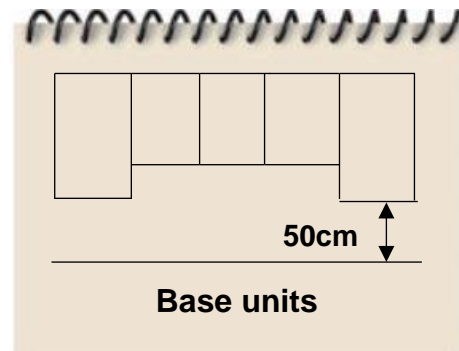
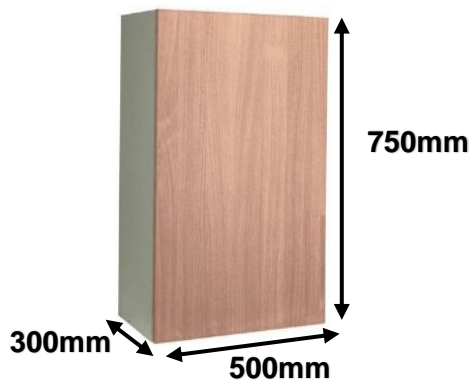

Use the scale plan of the elevation of the kitchen wall to show where the kitchen designer should draw the cupboards.

Space for working

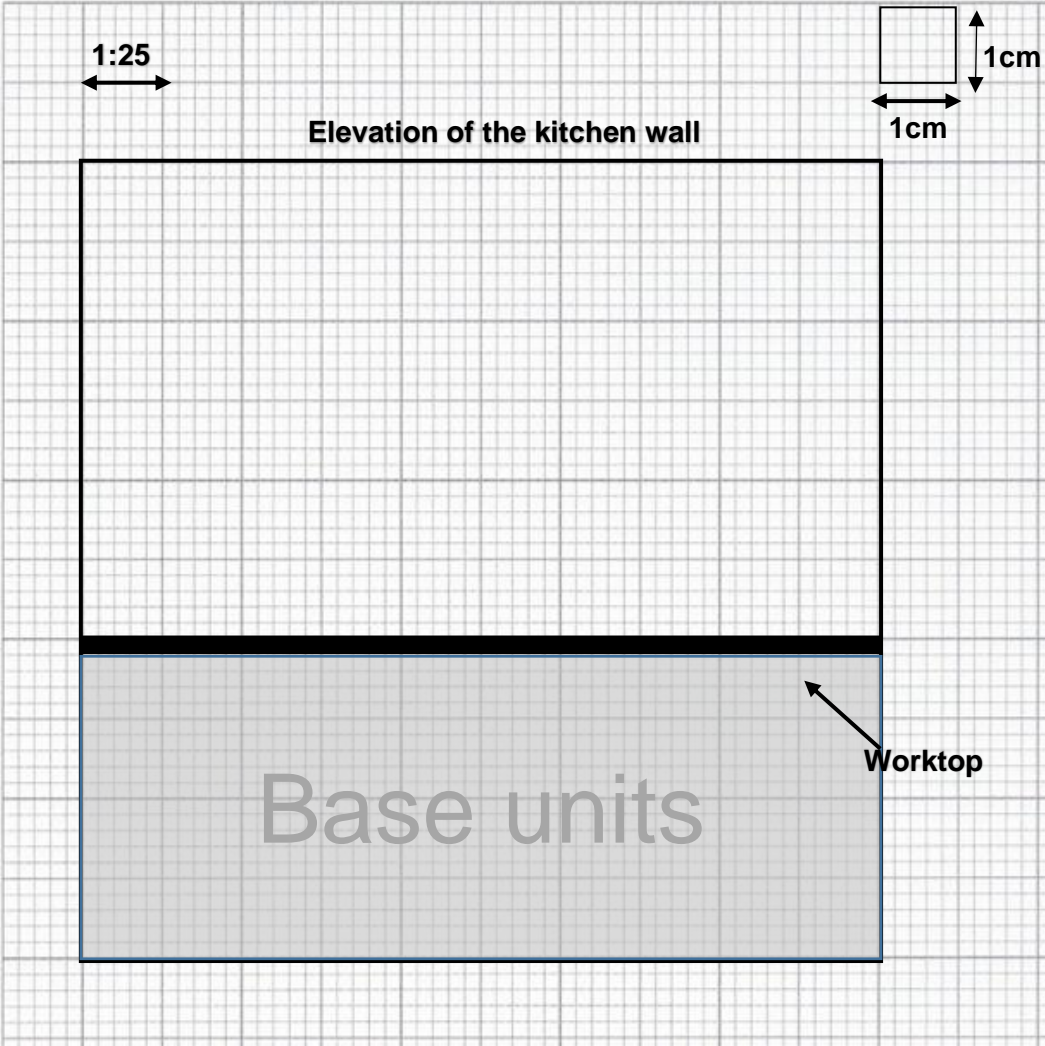

(6 marks)

Q15

A health club conducts a survey to compare the average number of hours of sleep of members.

Members report their results each week.

A woman takes part in this survey. She wears a fitness band, which records the number of hours she sleeps.

She wants to compare her own results week by week.

Last week she slept a mean time of 5 hours 19 minutes with a range of 4 hours 49 minutes.

This is the record for this week.

This week	Duration of sleep
Monday	8 hours 22 minutes
Tuesday	6 hours 49 minutes
Wednesday	5 hours 59 minutes
Thursday	5 hours 49 minutes
Friday	6 hours 44 minutes
Saturday	7 hours 16 minutes
Sunday	5 hours 55 minutes

What are the results that the woman reports to the health club?

What comparison can she make between her own results?

Make **two** comments using figures.

Show your working

Comment 1

Comment 2

(6 marks)

Spare graph paper for Question 14

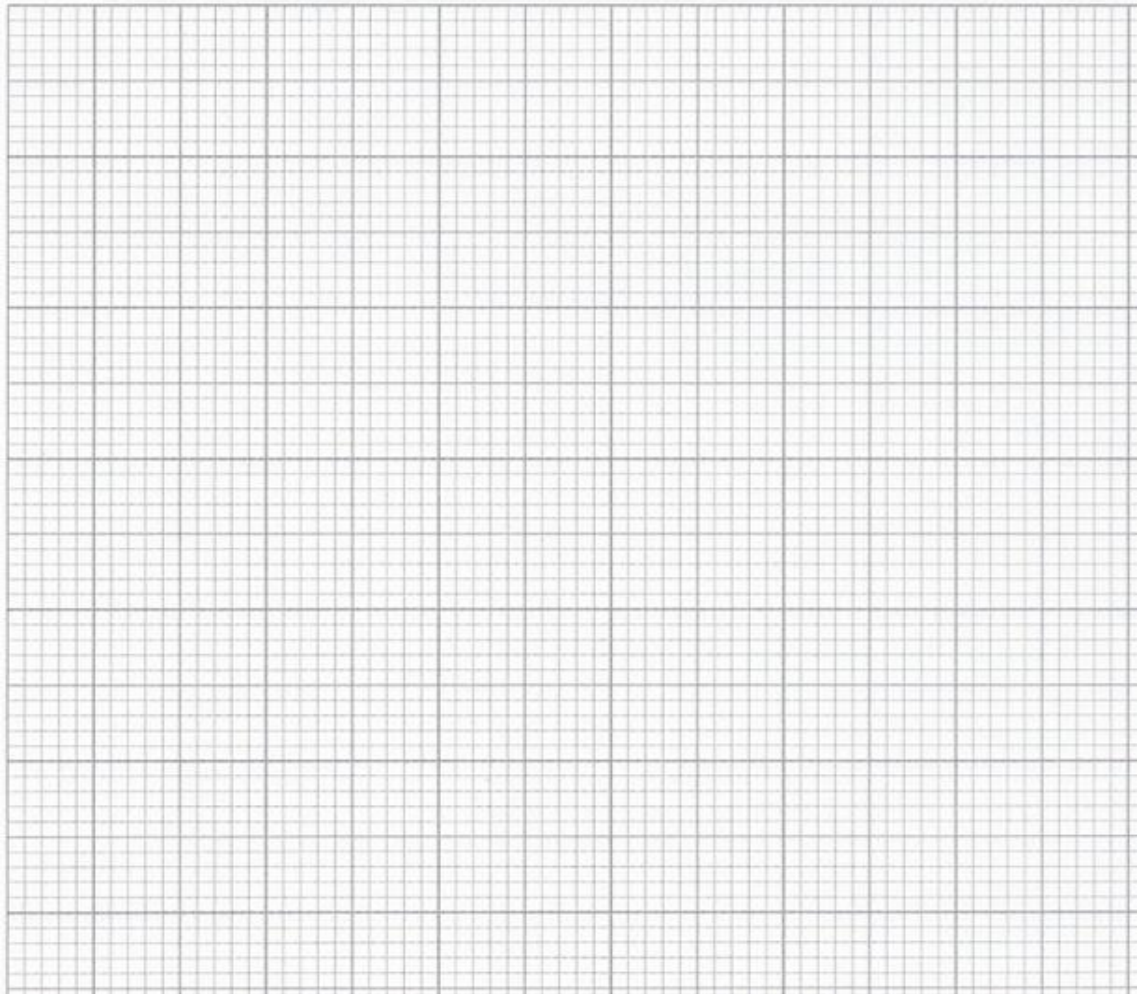

Extra space for working out and answers

End of section 2



Ready to Take Your Functional Skills Exam?

Exam Centre is offering Ofqual-regulated, City & Guilds approved Functional Skills Maths and English exams; the nationally recognised GCSE grade 4+ (grade C) equivalent. Whether you're sitting for the first time or resitting, we offer flexible exam bookings online and at our centre all year round.

 **Book Now!**

Book Your Exams & Courses

Qualification	Private Course	Online Exam	Exam in London
Functional Skills Maths Level 1 & 2	Enrol on Course	Book Online Exam	Book London Exam
Functional Skills English Level 1 & 2	Enrol on Course	Book Online Exam	Book London Exam

Why Exam Centre?

- Ofqual-regulated & fully accredited
- City & Guilds approved awarding body exams
- Accepted by employers, colleges, universities & apprenticeship providers
- Flexible online and in-person options across the UK
- Recognised GCSE Maths & English equivalent (grade 4+ / grade C)

CALL US FOR MORE INFORMATION:

 **020 7288 9020**

 booking@examcentre.co.uk

 www.examcentre.co.uk